

SINGLE LINE DIAGRAM OF 132/33 KV GSS DARBHANGA

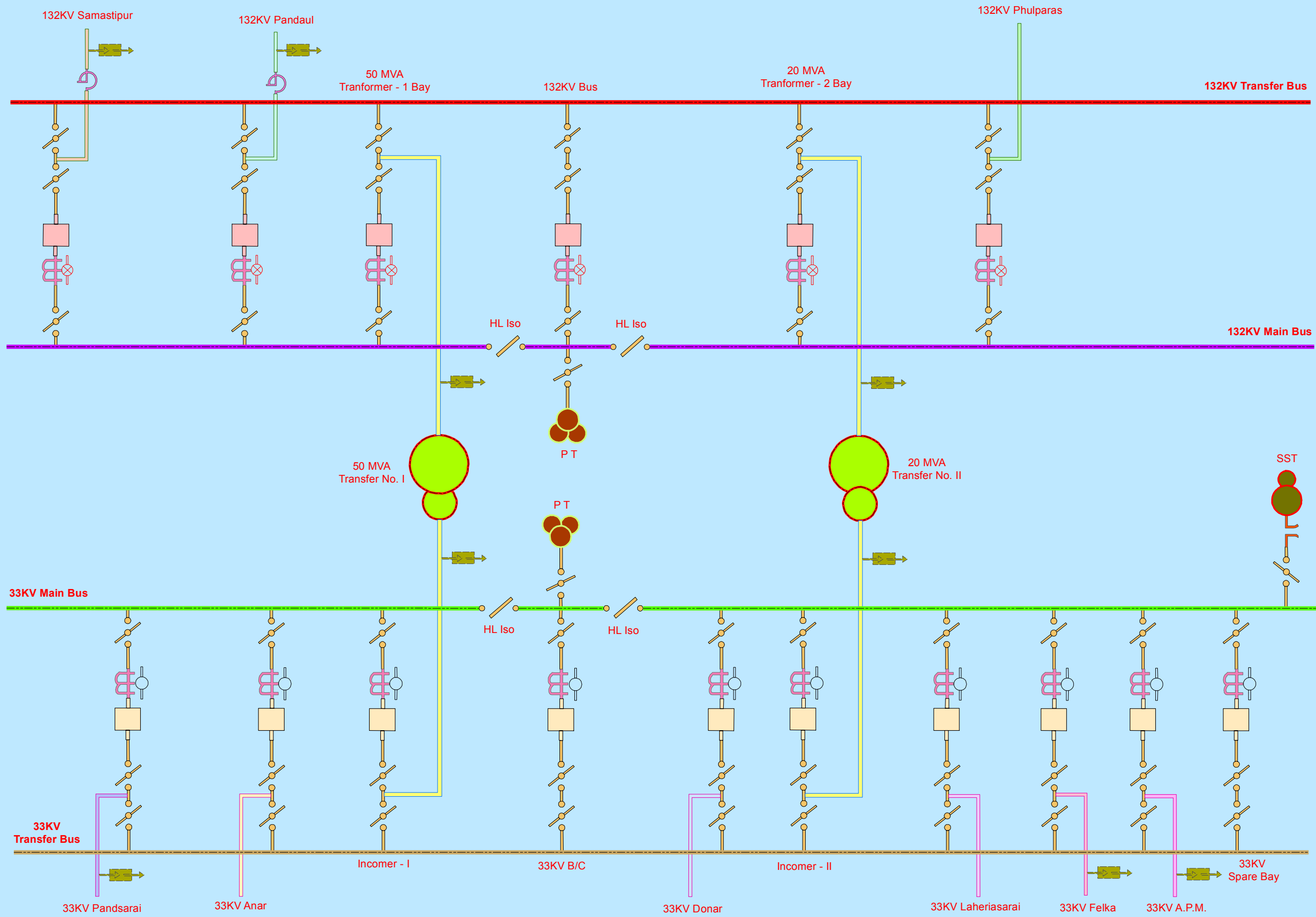

LEGEND

- 132 KV CIRCUIT BREAKER
- 33 KV CIRCUIT BREAKER
- ISOLATOR
- CURRENT TRANSFORMER
- POWER TRANSFORMER
- STATION TRANSFORMER
- POTENTIAL TRANSFORMER
- C V T
- SURGE ARRESTOR
- WAVE TRAP
- HORN GAP FUSE
- EARTH SWITCH
- CAPACITOR BANK
- OPERATIONAL METER
- ABT METER
- 132KV TRANSFER BUS
- 132KV MAIN BUS
- 33KV MAIN BUS
- 33KV TRANSFER BUS
- INCOMER
- 132KV PANDAU
- 132KV PHULPARAS
- 132KV SAMASTIPUR
- 33KV A.P.M.
- 33KV ANAR
- 33KV DONAR
- 33KV FELKA
- 33KV LAHERIASARAI
- 33KV PANDSARAI

PREPARED BY:



Authorized Signatory