

# Single Line Diagram Of GSS, Katihar

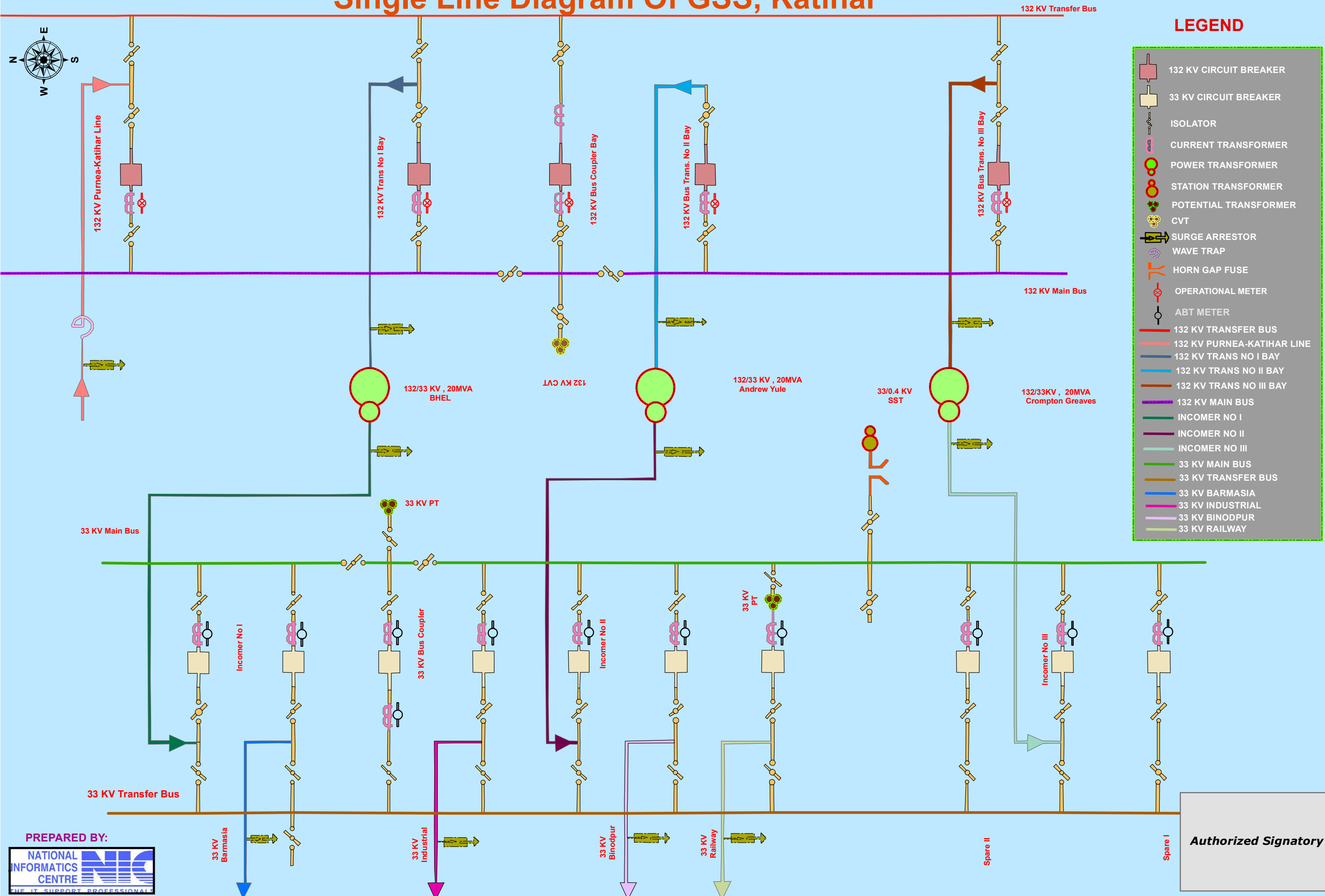

## LEGEND

- 132 KV CIRCUIT BREAKER
- 33 KV CIRCUIT BREAKER
- ISOLATOR
- CURRENT TRANSFORMER
- POWER TRANSFORMER
- STATION TRANSFORMER
- POTENTIAL TRANSFORMER
- CVT
- SURGE ARRESTOR
- WAVE TRAP
- HORN GAP FUSE
- OPERATIONAL METER
- ABT METER
- 132 KV TRANSFER BUS
- 132 KV PURNEA-KATI HAR LINE
- 132 KV TRANS NO I BAY
- 132 KV TRANS NO II BAY
- 132 KV TRANS NO III BAY
- 132 KV MAIN BUS
- INCOMER NO I
- INCOMER NO II
- INCOMER NO III
- 33 KV MAIN BUS
- 33 KV TRANSFER BUS
- 33 KV BARMASIA
- 33 KV INDUSTRIAL
- 33 KV BINODPUR
- 33 KV RAILWAY